

EP-6000 PARTS LIST

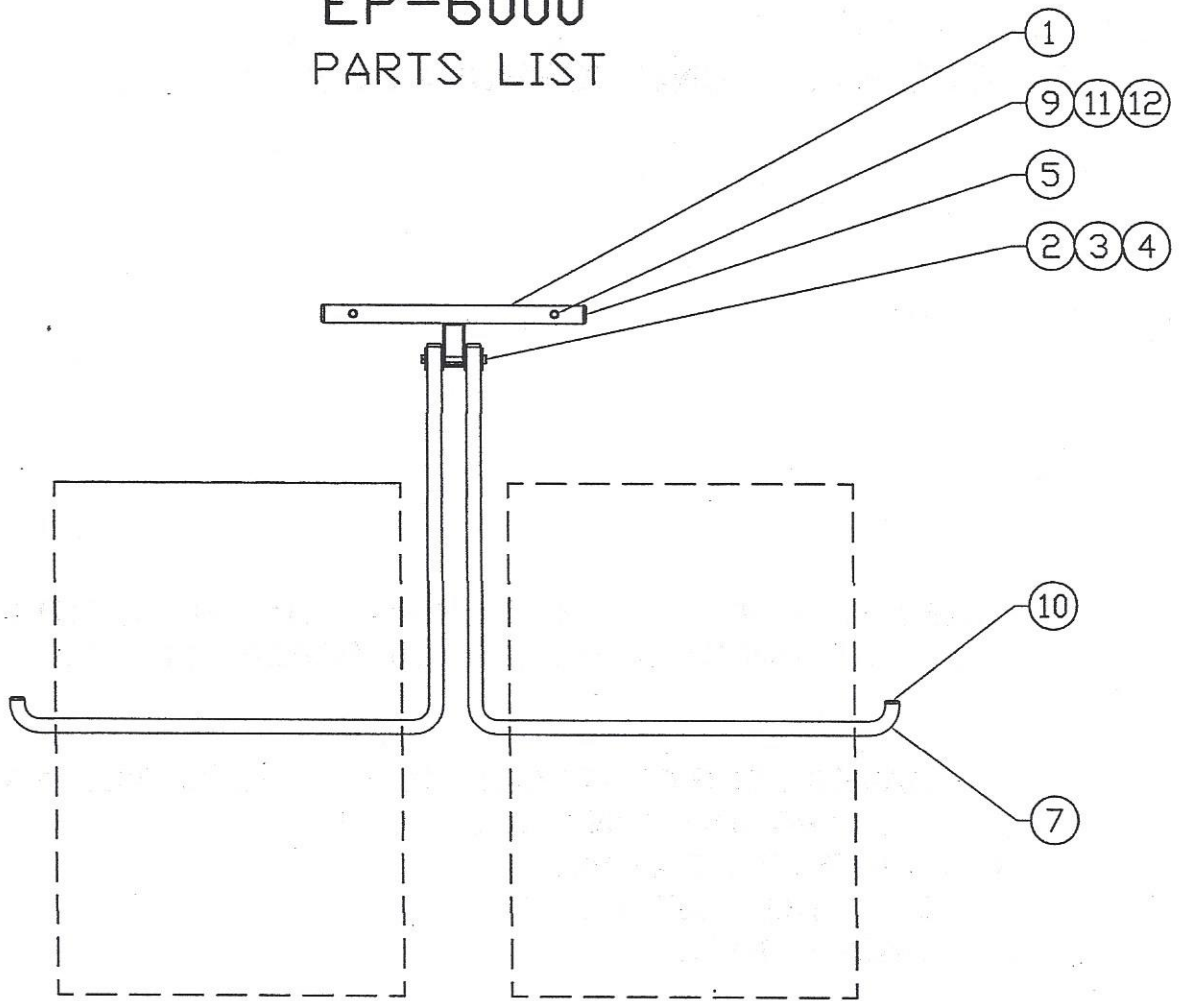

PLEASE NOTE:

IF UNIT IS INTENDED TO CARRY A SINGLE ROLL
INSTEAD OF TWO AS SHOWN, SUBSTITUTE 1
ITEM 22 SPACER FOR 1 SUPPORT ARM

Item	Description	Qty	Part #
1	MOUNT	1	E6000-01
2	SUPPORT ARM PIVOT SCR.	1	E6000-02
3	ARM PIVOT WASHER	4	E6000-03
4	ARM PIVOT NUT	1	E6000-04
5	SQUARE TUBE CAP-1 1/4	2	E6000-05
7	SUPPORT ARM	2	E6000-07

Item	Description	Qty	Part #
9	ANCHOR WASHER	2	E6000-09
10	TUBE CAP	6	E6200-10
11	MOUNTING SCREW	2	E6000-11
12	MOUNTING ANCHOR	2	E6000-12
22	SPACER	1	E6000-22

ITEMS DENOTED THUS **ABC** ARE MODEL SIZE SPECIFIC AND THE SIZE MUST BE GIVEN WHEN ORDERING THESE PARTS.

Always use proper lifting techniques, wear eye protection and
check to make sure all parts are properly serviced.