

EP-1410

FEED WHEEL TENSIONER

TOOL MAINTENANCE

This tool has been thoroughly inspected and tested before shipment. It is designed for Hard wear and long service.

The following simple instructions will aid you in prolonging the serviceability of this tool: Clean this tool periodically with a wire brush. Apply light machine oil to all moving parts.

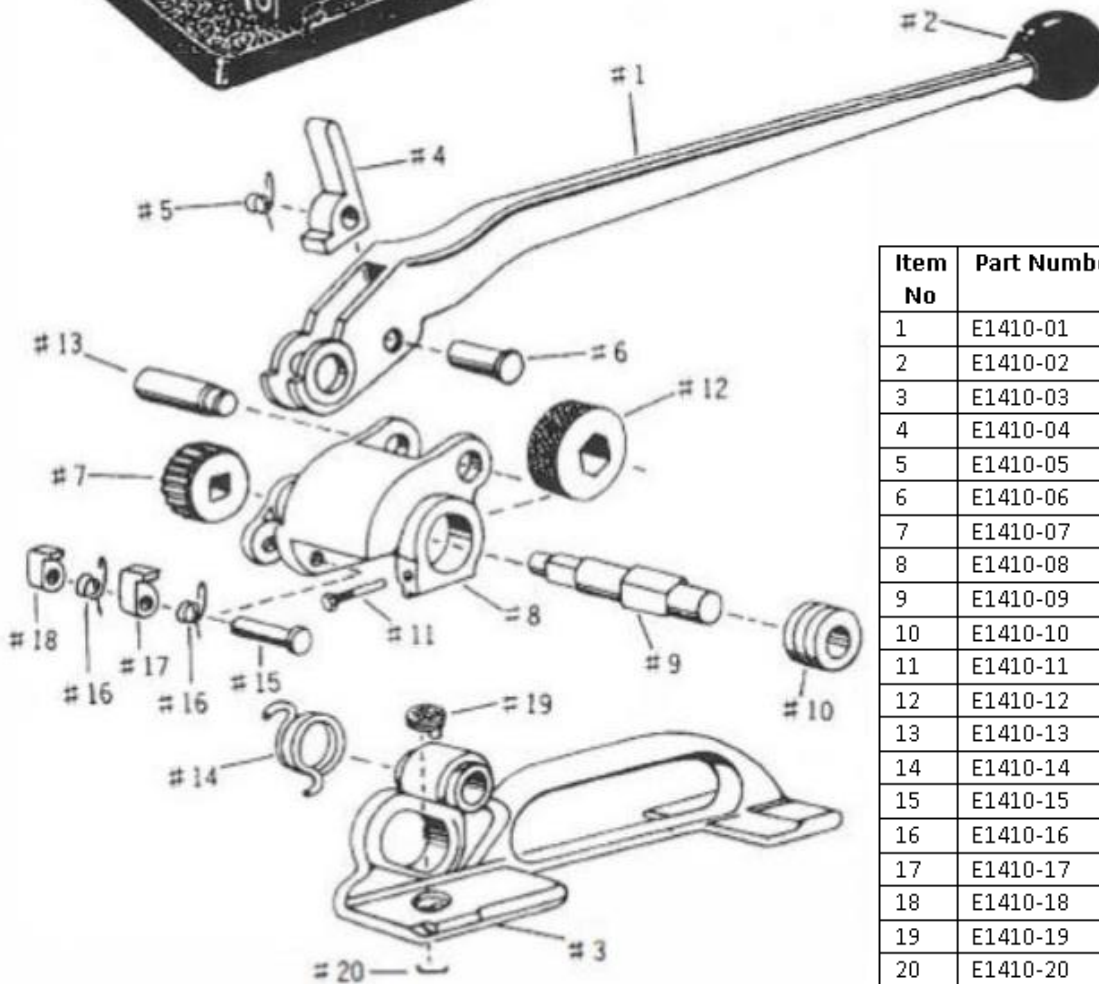
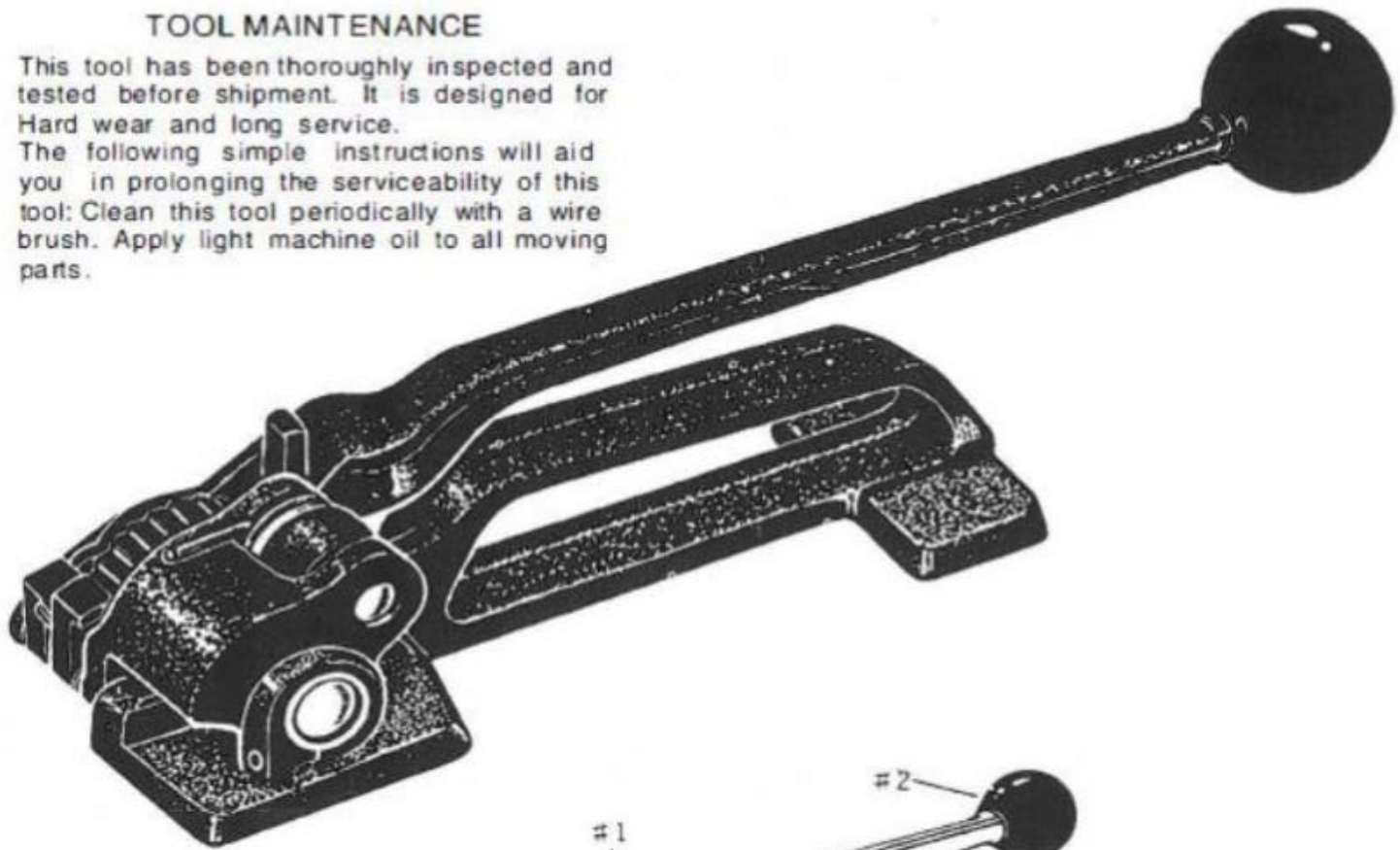

Item No	Part Number	Description	Qty
1	E1410-01	Handle	1
2	E1410-02	Knob	1
3	E1410-03	Base	1
4	E1410-04	Handle Pawl	1
5	E1410-05	Handle Pawl Spring	1
6	E1410-06	Crosshead Pin	1
7	E1410-07	Ratchet Gear	1
8	E1410-08	Support Frame	1
9	E1410-09	Shaft	1
10	E1410-10	Bushing	1
11	E1410-11	Cap Screw 3/16"	1
12	E1410-12	Feedwheel	1
13	E1410-13	Support Pin	1
14	E1410-14	Feedwheel Support Spring	1
15	E1410-15	Retaining Pawl Pin	1
16	E1410-16	Pawl Spring	2
17	E1410-17	Long Pawl	1
18	E1410-18	Short Pawl	1
19	E1410-19	Clutch Plug	1
20	E1410-20	Clutch Plug Pin	1